



www.fordvans.co.uk/peoplemovers

Ford People Movers

Backbone of Britain

Specification

April 2005



Dealer

Published by Commercial Vehicle Marketing,
Ford Motor Company Limited,
Brentwood, Essex, England.
Registered in England No. 235446.
April 2005.
© Ford Motor Company Limited.

Illustrations, descriptions and specifications. This catalogue was correct at the time of going to print. However, Ford policy is one of continuous product development. The right is reserved to change specifications, colours and prices of the models and items illustrated and described in this publication at any time. For the latest details always consult your Ford Transit Specialist Dealer. **Optional equipment.** Throughout this publication, wherever a feature is described as being an 'Option' or 'Optional Fitment/Pack', etc., you should assume that it will be at extra cost to the base vehicle, unless specifically stated to the contrary. All models and colour combinations are subject to availability.





Long wheelbase

- Dimensions (mm)
A 4525
B 2044
B 1795
C 1906/1981
D 864
E 2912
F 749
G 809
H 1293
I 1219
J 1313
K 1492
L 1184
M 1320
N 2714
O 1830
O 1986
O 2007
P 496/601
Q 1505
R 1552
S 166
W 3.5 (cu.m)[†]
W 1.83 (cu.m)[†]
W 3.07 (cu.m)[†]
W 4.2 (cu.m)[†]

- Additional information** (mm)
Interior – Front
 Effective headroom 1304
 Maximum effective legroom 1008
 Shoulder room 1382
 Hip room 1284
Interior – Rear
 Effective headroom 1270
 Maximum effective legroom 915
 Shoulder room 1564
 Hip room 1550
 Load length (2nd row seat to rear) 1172
 Load length (2nd row seat folded) 1529

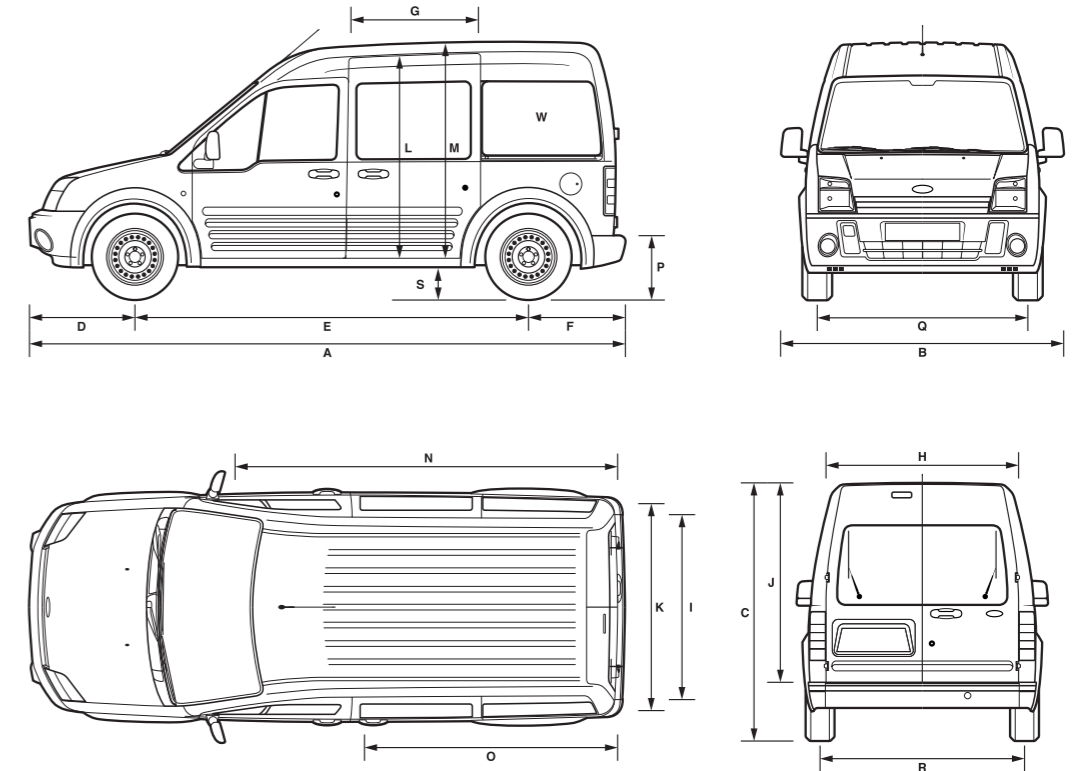

Tourneo Connect

- A** Overall length
- B** Overall width with mirrors
- B** Overall width without mirrors
- C** Overall height (laden/unladen)
- D** Front overhang
- E** Wheelbase
- F** Rear overhang
- G** Side door entry width
- H** Rear door opening width below belt

- I** Load width between wheel arches
- J** Rear door opening height
- K** Load width
- L** Side door opening height
- M** Load floor to roof
- N** Load length (max) (passenger's seat folded)
- O** Load length (laden to belt line)
- O** Load length (back of front seat)
- O** Load length (passenger's fold-flat seat up)

- P** Loading height (laden/unladen)
- Q** Front track
- R** Rear track
- S** Ground clearance
- W** Loadspace
- W** Loadspace (2nd row seat up)
- W** Loadspace (2nd row seat folded)
- W** Loadspace (passenger seat folded)

[†]Measured using the VDA method. Dimensions may vary dependent on the model and equipment fitted.

Ford Tourneo Connect

Highlights

- Flexible 5-seat accommodation
- Driver's and front passenger's airbags* standard on LX (passenger's airbag* optional, at extra cost on Tourneo Connect)
- Electronic anti-lock brakes (ABS) with electronic brake-force distribution
- 1.8-litre TDCi Common-Rail 90 PS / 220 Nm diesel engine
- Maximum cargo volume of 4.2 cu.m
- Removable 60:40 split back rear seats
- Central / double locking

When your vehicle has to work for a living and handle your leisure time too, making the right choice is doubly important.

Business demands are different from those of a family. But the Ford Tourneo Connect can comfortably satisfy both. Developed to change the way you work and play, it brings traditional Ford Transit toughness and durability to the dual-use market for the very first time.

***Note: A rear-facing child seat should never be placed in the front passenger seat when the Ford vehicle is equipped with an operational front passenger's airbag. The safest place for children is properly restrained on the rear seat.**

Model availability

	Tourneo Connect	LX
1.8 Duratorq TDCi (90 PS) diesel	●	●

● = Standard.

Weights and loads

	Payload (Gross) (kg) ^o	Gross vehicle mass (kg)	Kerb mass (kg) ^o	Rear axle ratio	Max. GTM (kg)* with quoted axle ratio
1.8 Duratorq TDCi (90 PS) diesel	800	2340	1540	4.06	3140

*Maximum 12% gradient. ^o **Payload** = Gross vehicle mass, less kerb mass. ^o **Rear axle ratio** = Represents the lightest kerbweight assuming full fluid levels and 90% fuel levels, subject to manufacturing tolerances and options, etc., fitted. **GVM** = Gross vehicle mass. The total permissible all-up weight of a rigid vehicle – i.e. with body, payload, ancillaries, fuel, oil, water, driver and crew. **Kerb mass** = The weight of the complete vehicle and all equipment including fuel and water, but without payload, driver or any crew. **GTM** = Gross train mass. The total permissible all-up weight of a rigid vehicle (see GVM) together with its trailer and load. All kerb masses quoted in this brochure are subject to manufacturing tolerances and are for vehicles with minimum equipment.

Engine data

	Engine technical features	Maximum power ^o	Maximum torque ^o
1.8 Duratorq TDCi Diesel 1753 cc	4 cylinders in line; SOHC; 8 valves; direct injection with high pressure, common-rail, multipoint fuel injection system; variable nozzle turbocharger with intercooler and transient torque overboost function; electronic throttle; dual-mass flywheel	66 kW (90 PS) at 4000 min ⁻¹ (rpm)	220 Nm at 1750 min ⁻¹ (rpm)

^oTested in accordance with ISO 1585.

Mechanical features

	Tourneo Connect	LX
Brakes		
Diagonally-split, with dual-line servo-assistance. Front discs, rear drums	●	●
Anti-lock brakes (includes electronic brake-force distribution)	●	●
Fuel tank		
Capacity – 60 litres	●	●
Steering		
Power-assisted	●	●
Steering column – Rake/reach-adjustable	●	●
Suspension and body		
Front – Independent with MacPherson struts, variable-rate coil springs, gas-pressurised shock absorbers, and anti-roll bar	●	●
Rear – Multi-leaf springs, gas-pressurised shock absorbers, and anti-roll bar	●	●
Side-impact door beams, front. Collapsible steering column. Energy absorbing crumple zones, front and rear	●	●
Towing eyes – Front and rear	●	●
Turning circle		
Kerb to kerb – 11.9 m	●	●

● = Standard.

Fuel, performance and emissions

	CO ₂ emissions (g/km) ^{oo}	Fuel consumption L/100 km (mpg) ^{oo}			Performance ^o		
		Urban	Extra urban	Combined	Max. speed (mph)	0-62 mph (secs)	30-50 mph* (secs)
1.8 Duratorq TDCi (90 PS) Diesel	172	7.9 (35.8)	5.8 (48.7)	6.5 (43.5)	96	16.3	14.9

*In 4th gear. ^oFord test figures. ^{oo}All CO₂ emissions figures in g/km and fuel consumption figures in L/100 km (mpg) are from officially approved tests in accordance with EEC Directive 1999/100/EC. The CO₂ emissions and fuel consumption test figures shown in the chart do not express or imply any guarantee of the emissions or fuel consumption of a vehicle of the class in question. All the figures are based on tests conducted on vehicles with standard wheels and tyres; optional or accessory wheels and tyres may have an effect on the emissions and fuel consumption of a vehicle. **Urban** An engine started from cold in laboratory conditions operated at varying speeds, maximum 31 mph, average 12 mph over a theoretical distance of 2.5 miles (4 km). **Extra Urban** Conducted immediately after the urban cycle, it consists of half steady speed driving and half varying speed driving, maximum 75 mph over a distance of 4.3 miles (7 km). **Combined** This is an average of the two parts of the test, weighted by the distances covered in each part. **Note:** All vehicles are 5-speed manual.

Safety and security

	Tourneo Connect	LX
Anti-lock brakes (includes Electronic Brake Distribution)	●	●
Anti-lock brakes (includes Electronic Brake Distribution) with traction assist and rear disc brakes	○	○
Side impact door beams, front. Collapsible steering column. Energy absorbing crumple zones, front and rear	●	●
Airbag – Driver's	●	●
– Front passenger's*	○	●
Airbags – Front side impact (not available with fold-flat passenger's seat)*	○	○
Alarm – Perimeter	○	○
Immobiliser – Passive Anti-Theft System (PATS)	●	●
Locks – High-security, lock-in-latch system, shielded with strengthened mountings	●	●
– Remote keyless entry	●	●
– Central/double locking	●	●
Key-operated bonnet release	●	●
Fuel cap – Locking with body colour flap	●	●
Vehicle Identification Number (VIN) – Visible	●	●

● = Standard, ○ = Option, at extra cost. *Note: A rear-facing child seat should never be placed in the front passenger's seat when the Ford vehicle is equipped with a front passenger's or side airbags.

Exterior features

	Tourneo Connect	LX
Exterior appearance and styling		
Bodyside mouldings – One-piece, self colour	●	●
Bumpers – Self colour	●	●
Paint – Metallic	○	●+
Wheel-lip mouldings – Self colour	●	●
Exterior functional		
Door mirrors – Manual, flat folding, black housings	●	
– Enhanced rear vision	●	●
– Electrically-operated and heated, black housings	□	●
Doors – Hinged rear doors, glazed	●	●
– Driver and passenger side sliding load doors, glazed	●	●
Heated rear window(s)	□	●
Winter Pack – Electrically-operated and heated door mirrors, 'Quickclear' heated front windscreen (includes heated washer jets)	○	
Rear Vision Pack – Rear wiper with fixed intermittent wipe and electric wash, heated rear window(s)	○	●
Parking distance sensor – Rear	○	○
Tinted glass – Front door windows and windscreen only	●	●
– Heavy tint privacy, all rear windows	□	□
Towing eyes – Front and rear	●	●
Windscreen – Laminated	●	●
– 'Quickclear' heated front (includes heated washer jets)	□	●
Wipers – Front, 2-speed, with intermittent wipe and electric wash	●	●
– Rear, with fixed intermittent wipe and electric wash	□	●
Halogen headlights, side lights, rear fog lights, reversing lights	●	●
High-mounted rear brake light	●	●
Fog lights – Front	○	●

● = Standard, ○ = Option, at extra cost, □ = Part of an option pack, at extra cost, ●+ = Option, at no extra cost.

Interior features

	Tourneo Connect	LX
Audio		
Stereo AM/FM radio/cassette – Model 4000 RDS, 'Keycode' anti-theft coding, 2 speakers	●	
Stereo AM/FM radio/CD – Model 6000N RDS EON, 'Keycode' anti-theft coding, 2 speakers	□	●
– Model 6006E RDS EON, with 6-disc in-dash CD autochanger, 'Keycode' anti-theft coding, 2 speakers	□	○
Option Pack 14 – Stereo AM/FM radio/CD, Model 6006E RDS EON with 6-disc in-dash CD autochanger, 'Keycode' anti-theft coding, steering column-mounted remote audio controls	○	
Option Pack 13 – Stereo AM/FM radio/CD, Model 6000N RDS EON, 'Keycode' anti-theft coding, steering column-mounted remote audio controls	○	●
Speaker upgrade – 4 speakers in lieu of 2 (not available with 4000 RDS)	○	○
Steering column-mounted remote audio controls (not available with 4000 RDS)	□	●
Carpet and trim		
Carpet – Non-woven velour	●	●
Door trim – Moulded panel with pull handles and, on front doors only, door bins	●	●
Gear lever gaiter – Black	●	●
Gear knob – Black with acrylic insert	●	●
Interior lighting		
Courtesy light – Header-mounted, front door-operated	●	●
Load compartment lights – Two, roof-mounted	●	●
Instruments and controls		
Control stalks – Column-mounted for master lights, indicators and wash/wipe functions	●	●
Illuminated heater controls – 4-speed fan. Four vents with temperature and direction control	●	●
Instruments – Speedometer, engine temperature, fuel level gauges, tachometer and trip recorder	●	●
Warning indicators for oil pressure, direction indicators, glow plugs, main beam, ignition/alternator, brake failure, handbrake on, airbag(s), low fuel level, 'lights on' audible warning, ABS, traction control, check engine	●	●
Steering wheel – Black	●	●
Seats and seat belts		
Front seat – Driver's 4-way manual adjustment	●	
– Driver's 6-way manual adjustment	○	●
– Passenger's 4-way manual adjustment (includes under seat storage)	●	●
– Driver's armrest and adjustable lumbar support	○	○
– Passenger's fold-flat seat for loadbox extension	○	○
Front seats – Anti-submarining, fully reclining with height-adjustable head restraints	●	●
Storage pockets – Driver's and front passenger's seat back (not available on fold-flat seat)	●	●
Rear seat – Folding back, removable	●	●
– 40:60 split back	●	●
Rear seats – Head restraints on all seats	●	●
Seat trim – Fabric	●	●
– Prima grain vinyl	○	
Seat belts – Front, inertia reel, with grabbers, static buckle and roto pre-tensioner (driver's seat only) and height-adjustable mounts	●	●
– Rear, inertia reel lap and diagonal	●	●
Comfort and convenience		
Accessory socket	●	●
Air conditioning – CFC-free with air recirculation	○	●
Centre console – Includes coin tray, pen holder and 2 cup holders	●	●
Clock – Digital	●	●
Coat hooks – 4	●	●
Glovebox	●	●
Grab handle – Passenger's front	●	●
Heater – Recirculation	●	●
Mirror – Dipping rear-view	●	●
Privacy Pack – Cargo tonneau cover and heavy tint privacy glass on all rear windows	○	○
Smokers' Pack – Cigar lighter and ashtray	○	○
Storage – Centre fascia-mounted clipboard holder	●	●
– Under passenger's seat, lockable (included with 4-way manual adjustment passenger seat)	●	●
Sun visor – Driver's with ticket strap	●	●
– Passenger's with covered mirror	●	●
Windows – Front, electrically-operated with 'one touch' lowering on driver's	○	●
Luggage compartment		
Load liner – Floor	●	●
– Half-height sidewall liner and wheel arch liner	●	●
Storage – Door stowage bin and net	●	●
Tie-down 'D' rings – Four	●	●
Cargo tonneau cover	□	□

● = Standard, ○ = Option, at extra cost, □ = Part of an option pack, at extra cost.

Special Vehicle Options

	Tourneo Connect	LX
250° Rear doors	○	○
SVO Paint package	○	○

○ = Option, at extra cost.

Wheel availability

	Tourneo Connect	LX
Wheels – 6x15" steel with full wheelcover (full-size spare) and 195/65 R15 tyres	●	●
– 15" 5-spoke alloy wheels (full-size steel spare) and 195/65 R15 tyres	○	○

● = Standard, ○ = Option, at extra cost.



8/9-seat Tourneo

- Front-Wheel Drive
Dimensions (mm)
A 4834
B 2360/1974
C 1970/1974
D 904
E 2933
F 997
G 1030
H 1540
I 1390
J 1370
K 1352
L 518 (unladen)
L 440 (laden)

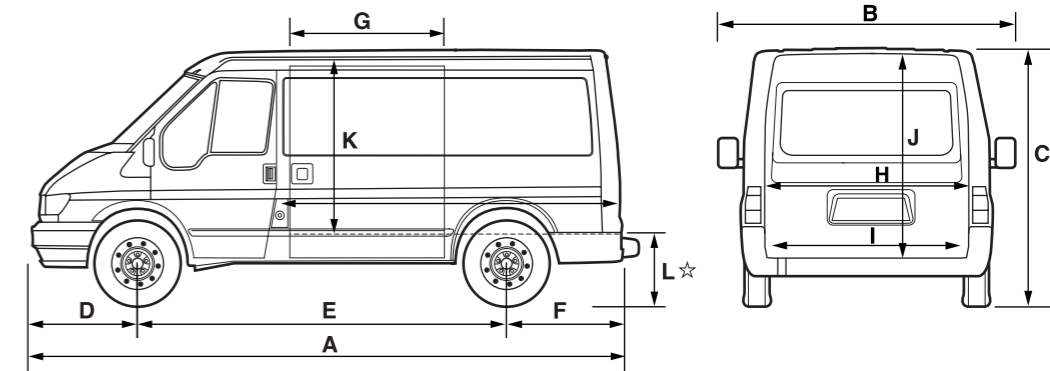

Tourneo

- A** Overall length (excluding rear step)
- B** Overall width (with/without mirrors)
- C** Unladen height*
- D** Front of vehicle to front wheel centre
- E** Wheelbase
- F** Rear of vehicle to rear wheel centre
- G** Side door entry width
- H** Rear door entry width
- I** Floorspace between wheel arches
- J** Rear door/tailgate entry height
- K** Side door entry height
- L** Loading height*

Key: All dimensions (shown in mm) are subject to manufacturing tolerances and refer to minimum specification models and do not include additional equipment. ☆Height dimensions show the range from minimum to maximum of a fully laden, lowest payload vehicle to unladen highest payload vehicle. These illustrations are for guidance only.

Model availability

	Driveline	8-seat GLX	9-seat
Tourneo			
2.0 Duratorq TDCi Diesel 92 kW (125 PS)	FWD	●	●

● = Standard.

Weights and loads

	Payload (gross) (kg)	Gross vehicle mass (kg)	Kerb mass (kg)	Front axle plated mass (kg)	Front axle kerb mass (kg)	Rear axle plated mass (kg)	Rear axle kerb mass (kg)	Axle ratio	Max. GTM (kg) with quoted axle ratio
8-seat GLX (280 SWB)									
2.0 TD 125 PS	840	2800	1960	1400	1086	1550	874	4.23	4500
2.0 TD 125 PS	840	2800	1960	1400	1086	1550	874	4.54	4500
9-seat (280 SWB)									
2.0 TD 125 PS	840	2800	1960	1400	1094	1550	866	4.23	4500
2.0 TD 125 PS	840	2800	1960	1400	1094	1550	866	4.54	4500

Key: **Payload** = Gross vehicle mass, less kerb mass. **GVM** = Gross vehicle mass. The total permissible all-up weight of a rigid vehicle – i.e. with body, payload, ancillaries, fuel, oil, water, driver and crew. **Kerb mass** = The weight of the complete vehicle and all equipment including fuel and water, but without payload, driver or any crew. **Plated mass** = The maximum weight allowed to be imposed on the axle (GVM must not be exceeded). **GTM** = Gross train mass. The total permissible all-up weight of a rigid vehicle (see GVM) together with its trailer and load. All kerb masses quoted in this brochure are subject to manufacturing tolerances and are for vehicles with minimum equipment.

FordTourneo

Highlights

- Available in 8- and 9-seat models
- Driver's and outer front passenger's airbags*
- Electronic anti-lock brakes (ABS) with electronic brake-force distribution and Traction Assist
- 2.0-litre TDCi Common-Rail 125 PS / 285 Nm diesel engine
- Short wheelbase, front-wheel drive configuration
- Front air conditioning
- Tinted windows
- Central / double locking with remote keyless entry

Don't split-up the board of directors, take the Ford Tourneo instead. With up to nine seats, including the driver, there's bags of room for everyone and their luggage too. From an airport shuttle to an executive taxi, the Ford Tourneo is the perfect way to conduct your business affairs.

***Note: A rear-facing child seat should never be placed in the front passenger seat when the Ford vehicle is equipped with an operational front passenger's airbag. The safest place for children is properly restrained on the rear seat.**

Engine data

	Engine technical features	Maximum power ^o	Maximum torque ^o
2.0 Duratorq TDCi Diesel 92 kW (125 PS) 1998 cc	4 cylinders in line; DOHC; 16 valves; alloy cylinder head; direct injection with high pressure, common rail, multipoint fuel injection system; turbocharger with intercooler and transient torque overboost function; electronic throttle; dual mass flywheel; catalytic converter.	92 kW (125 PS) at 3800 min ⁻¹ (rpm)	285 Nm at 1500-2200 min ⁻¹ (rpm)

All models are 5-speed manual transmission. ^oTested in accordance with ISO 1585.

Fuel, performance and emissions

	Axle ratio	CO ₂ emissions (g/km) ^{oo}	Fuel consumption L/100 km (mpg) ^{oo}		
			Urban	Extra Urban	Combined
Tourneo and Tourneo GLX					
2.0 TD 92 kW (125 PS)	4.23	208	9.3 (30.4)	6.6 (42.8)	7.6 (37.2)
	4.54	208	9.4 (30.1)	6.7 (42.2)	7.7 (36.7)

^{oo}All CO₂ emissions figures in g/km and fuel consumption figures in L/100 km (mpg) are from officially approved tests in accordance with EEC Directive 1999/100/EC. The CO₂ emissions and fuel consumption test figures shown in the chart do not express or imply any guarantee of the emissions or fuel consumption of a vehicle of the class in question. All the figures are based on tests conducted on vehicles with standard wheels and tyres; optional or accessory wheels and tyres may have an effect on the emissions and fuel consumption of a vehicle. **Urban** An engine started from cold in laboratory conditions operated at varying speeds, maximum 31 mph, average 12 mph over a theoretical distance of 2.5 miles (4 km). **Extra Urban** Conducted immediately after the urban cycle, it consists of half steady speed driving and half varying speed driving, maximum 75 mph over a distance of 4.3 miles (7 km). **Combined** This is an average of the two parts of the test, weighted by the distances covered in each part. **Note:** All vehicles are 5-speed manual.

Mechanical features

	8-seat GLX	9-seat
Engine		
Road speed limiter (max. 70 mph) (diesel engines only)	○	○
Brakes		
Dual-circuit, with self-adjusting servo-assistance. Front discs and rear drums	●	●
Electronic anti-lock brakes (with electronic brake-force distribution)	●	●
Traction Assist	●	●
Front brakes – Brake pad wear indicator	●	●
Fuel tank		
80 litres	●	●
Steering		
Power-assisted steering	●	●
Suspension		
Front, independent MacPherson struts, variable rate coil springs and gas-pressurised shock absorbers.	●	●
Rear, leaf springs and gas-pressurised shock absorbers	●	●
Front – Anti-roll bar	●	●
Axle ratios		
Final drive ratio – 4.23 (Front-Wheel Drive vehicles only)	●	●
– 4.54 (Front-Wheel Drive vehicles only)	●	●
Turning circle		
Kerb to kerb – 10.8 m, wall to wall 11.4 m	●	●

● = Standard, ○ = Option, at extra cost.

Safety and security

	8-seat GLX	9-seat
Safety		
Anti-lock brakes – Electronic (with electronic brake-force distribution)	●	●
Traction Assist (includes anti-lock brakes)	●	●
Airbag – Driver	●	●
– Outer front passenger*	●	●
Exterior mirrors – Enhanced rear vision	●	●
Seat belts – 3-point lap and diagonal inertia reel with grabbers (all front seats)	●	●
– 3-point lap and diagonal inertia reel with grabbers (all rear seats)	●	●
– Height-adjustable seat belt mount (driver only)	●	●
– Height-adjustable seat belt mount (outer front passenger)	●	●
Security		
Audio – 'Keycode' anti-theft coding	●	●
– Removable control panel	●	●
Alarm – Perimeter (Standard on Tourneo GLX)	●	○
Fuel cap – Locking	●	●
Immobiliser – 'Safeguard' Passive Anti-Theft System – (certified to Thatcham Category 2)	●	●
Locks – High security, lock-in-latch system, shielded with strengthened mountings	●	●
– Remote keyless entry central, double locking	●	●
– Key-operated bonnet release	●	●
– 2nd remote control key fob	○	○
Steering wheel – Torque slip, anti-theft	●	●
Vehicle Identification Number – Visible	●	●

● = Standard, ○ = Option, at extra cost. *Note: A rear-facing child seat should never be placed in the front passenger's seat when the Ford vehicle is equipped with a front passenger's or side airbags.

Exterior features

	8-seat GLX	9-seat
Exterior appearance and styling		
Body – Low roof	●	●
Bodyside mouldings	●	○
Bumpers – Full width, front and rear	●	●
Paint – Metallic	○	○
Tyres – Goodyear (Mud and snow) (not available with alloy wheel option)		○
– Michelin (All-weather) (not available with alloy wheel option)		○
Wheels – 5½x15" steel wheels with centre hub covers and 195/70R 15C tyres		●
– 5½x16" alloy wheels (steel spare) and 205/65R 16C tyres	●	○
– Partial wheelcovers		●
Exterior functional		
Doors – With drop window and winder handle		●
– With power window and control	●	
– Left-hand sliding side door (low/narrow)	●	●
– Right-hand sliding side door (low/narrow)	●	●
– Glazed rear doors (includes rear-view mirror) 180° opening, positive stop at 90°. On Tourneo models this option includes heated rear windows, twin rear wipers and high-mounted rear brake light	○	○
– Rear tailgate (includes heated rear window)	●	●
Exterior mirrors – Power-operated and heated	●	○
Mudflaps – Front	●	●
– Rear	○	○
Towing eyes – Front and rear	●	●
Tow bar (not available with optional integrated bumper step, rear centre step or rear parking distance sensor) with 13-pin electrics (tachograph may be required, dependent on model)*	○	○
Windows – Front, power-operated	●	○
– Heated rear	●	●
– 2nd row, right-hand side, fixed	●	
– 2nd row, right-hand side, sliding		●
– 2nd row, left-hand side, fixed	●	
– 2nd row, left-hand side, sliding		●
– 3rd row, left-hand and right-hand side, rear quarter, fixed	●	●
Glass – Light tint windscreen/dark tint passenger glass	●	●
Windscreen – Laminated	●	●
– ‘Quickclear’ heated	○	○
Wipers – Front, two-speed with electric wash	●	●
– Tailgate, with electric wash (includes high-mounted rear brake light)	●	●
Exterior lighting		
Halogen headlights, side lights, rear fog lights, reversing lights	●	●
Front fog lights	○	○
Headlight levelling	●	●
High-mounted rear brake light	●	●

● = Standard, ○ = Option, at extra cost.

Interior features

	8-seat GLX	9-seat
Audio		
Stereo radio/cassette – Model 4000 RDS, ‘Keycode’ anti-theft coding, removable control panel, 4 speakers	○	●
Stereo radio/CD – Model 6000 RDS, ‘Keycode’ anti-theft coding, removable control panel, 4 speakers	●	○
Carpet and trim		
Cab headlining – Moulded	●	●
Door trim – Front, moulded with pull handles and storage pockets	●	●
Carpet – Full length	●	●
Headlining – Moulded full length	●	●
Interior lighting		
Courtesy lights – Header-mounted, front door-operated	●	●
Passenger area light(s)	●	●
Instruments and controls		
Cold start (Thermostart for -20°C starting)	●	●
Control stalks – Column-mounted for indicators and wash/wipe functions	●	●
Illuminated heater controls – 3-speed fan. Four vents with temperature and direction control, two dedicated side window demisters	●	●
Instruments – Speedometer, tachometer, odometer, fuel gauge, water temperature gauge, trip recorder	●	●
Tachograph – Electronic, 24-hour*	○	○
Warning lights for oil pressure, direction indicator, main beam, lights on, ignition/alternator, brake failure, ABS, airbag(s), glow plugs, oil change, low fuel, traction control	●	●
Seats		
Seat trim – Fabric	●	●
Seats – Premium fabric trim; driver’s 8-way manual adjustment with armrests; dual fixed passengers’ seat; height-adjustable head restraints	○	●
– Premium fabric trim; driver’s heated, 8-way manual adjustment with armrests; single passenger’s heated, 8-way manual adjustment with armrests; height-adjustable head restraints	●	○
Second row – Triple narrow seat with split back on outer seat (left-hand side) includes armrests on Tourneo GLX	●	●
Third row – Triple/fold and roll seat (removable) includes armrests on Tourneo GLX	●	●
Seat belts – Height-adjustable mount, driver’s side	●	●
– Height-adjustable mount, outer front passenger	●	●
Comfort and convenience		
Accessory socket 12V	○	○
Air conditioning – Front, CFC-free	●	●
– Rear, CFC-free (only available with Front air conditioning) (2nd row LHS & RHS sliding windows replaced with fixed glass with this option)	●	○
Rear compartment heating (not available with rear air conditioning)		○
Clock – Digital	●	●
Cup holder – Twin, facia-mounted, drop-down	●	●
Glovebox – With lid	●	●
Smokers’ Pack – Cigar lighter and ashtray	○	○
Storage – Front door pocket	●	●
– Facia-mounted on passenger’s side, with cup holder	●	●
– Centre facia-mounted document holder, with integral cover	●	●
– Facia-mounted stowage slot	●	●
Steering wheel – Leather-covered	●	
Sun visors – Two, swivelling (passenger visor includes mirror)	●	●

● = Standard, ○ = Option, at extra cost. *Tachograph When a vehicle is fitted with a trailer towing attachment, it is recommended that a tachograph is fitted, since the ability to tow a trailer giving a GTM of over 3500 kg without a tachograph could be considered to be contrary to EU and UK road traffic law.



12-Seat Bus

Front-Wheel Drive
Dimensions (mm)
A 5201
B 2360/1974
C 2309
D 904
E 3300
F 997
G 2250
H 1540
I 1390
J 1666
K 1565
L 532 (unladen)
L 440 (laden)

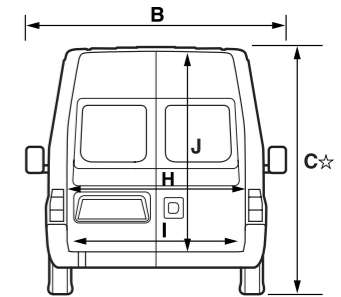
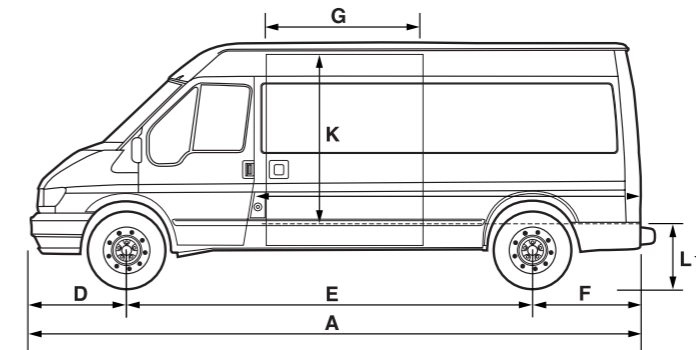

15-Seat Bus

Rear-Wheel Drive
Dimensions (mm)
A 5651
B 2360/1974
C 2315-2354
D 904
E 3750
F 997
G 690
H 1540
I 1390
J 1566
K 1465
L 668 (unladen)
L 576 (laden)

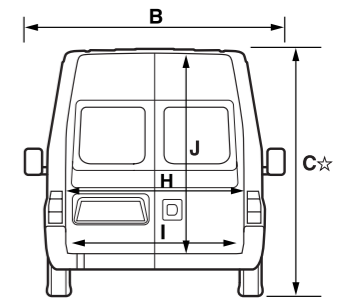
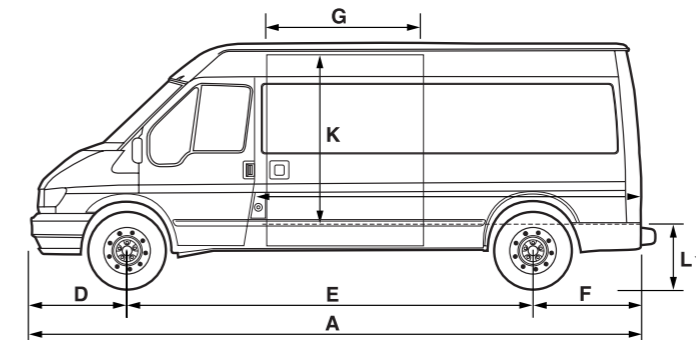

17-Seat Bus

Rear-Wheel Drive
Dimensions (mm)
A 6374
B 2360/2084
C 2340
D 904
E 3750
F 1702
G 690
H 1540
I 1153
J 1566
K 1465
L 691 (unladen)
L 615 (laden)

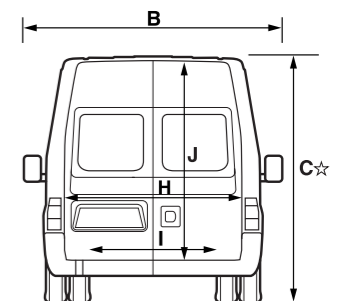
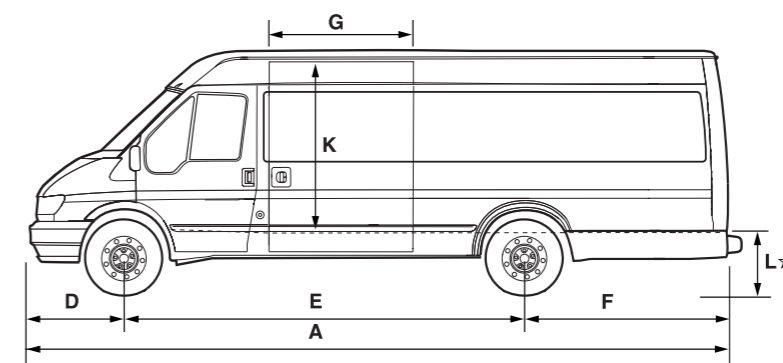

Ford Transit Minibus



Highlights

- Available in 12-, 15- and 17-seat models
- Driver's and outer front passenger's airbags*
- All seats and fixings tested to meet strict safety standards
- Three-point lap-and-diagonal inertia reel seat belts
- Seat belts tested to perform under a mean deceleration of 20 G - twice the normal M2 (commercial) test
- Electronic anti-lock brakes (ABS) with electronic brake-force distribution
- 'Schedule 6' pack
- New optional 2.4-litre TDCi Common-Rail 137 PS / 375 Nm diesel engine with six-speed manual transmission

The award-winning Ford Transit Minibus range offers generous accommodation for up to 17 people. So taking the football team to an away game is never a problem. A light and airy interior with comfortable seating makes every journey a pleasure, while industry-leading levels of safety and security allow you further opportunities to relax.

***Note: A rear-facing child seat should never be placed in the front passenger seat when the Ford vehicle is equipped with an operational front passenger's airbag. The safest place for children is properly restrained on the rear seat.**

All Minibuses

- A Overall length (excluding rear step)
- B Overall width (with/without mirrors)
- C Unladen height*
- D Front of vehicle to front wheel centre
- E Wheelbase
- F Rear of vehicle to rear wheel centre
- G Side door entry width
- H Rear door entry width
- I Floorspace between wheel arches
- J Rear door entry height
- K Side door entry height
- L Loading height*

Key: All dimensions (shown in mm) are subject to manufacturing tolerances and refer to minimum specification models and do not include additional equipment. ☆Height dimensions show the range from minimum to maximum of a fully laden, lowest payload vehicle to unladen highest payload vehicle. These illustrations are for guidance only.

Model availability

Ford Transit Minibus	Driveline	12-seat	15-seat	17-seat
2.0 Duratorq TDDi Diesel 74 kW (100 PS)	FWD	●		
2.4 Duratorq TDDi Diesel 66 kW (90 PS)	RWD		●	●
2.4 Duratorq TDDi Diesel 85 kW (115 PS)	RWD		●	●
2.4 Duratorq TDCi Diesel 101 kW (137 PS)	RWD		●	●

● = Standard. FWD = Front-Wheel Drive. RWD = Rear-Wheel Drive.

Weights and loads

	Payload (gross) (kg)	Gross vehicle mass (kg)	Kerb mass (kg)	Front axle plated mass(kg)	Front axle kerb mass (kg)	Rear axle plated mass (kg)	Rear axle kerb mass (kg)	Axle ratio	Max. GTM (kg) with quoted axle ratio
12-seat Minibus (300 MWB)									
2.0 TD 100 PS	1070	3150	2080	1500	1165	1700	915	4.23	4000
2.0 TD 100 PS	1070	3150	2080	1500	1165	1700	915	4.54	4500
15-seat Minibus (350 LWB)									
2.4 TD 90 PS/115 PS	1190	3500	2310	1650	1236	2100	1074	4.63	4500/5000 ^{††}
2.4 TD 90 PS/115 PS	1190	3500	2310	1650	1236	2100	1074	5.13	5750 ^{††}
2.4 TD 137 PS	1175	3500	2325	1650	1246	2100	1079	3.77	5750 ^{††}
2.4 TD 137 PS	1175	3500	2325	1650	1246	2100	1079	4.27	6000 ^{††}
17-seat Minibus (430 LWB EF)									
2.4 TD 90 PS/115 PS	1510	4100	2590	1650	1215	2950	1375	5.13	5750
2.4 TD 137 PS	1495	4100	2605	1650	1225	2950	1380	3.77	5750
2.4 TD 137 PS	1495	4100	2605	1650	1225	2950	1380	4.27	6000

^{††}GTM on 115 PS and 137 PS engines reduced to 4000 kg with optional rear air conditioning. **SWB** = Short wheelbase. **MWB** = Medium wheelbase. **LWB** = Long wheelbase. **Key: Payload** = Gross vehicle mass, less kerb mass. **GVM** = Gross vehicle mass. The total permissible all-up weight of a rigid vehicle – i.e. with body, payload, ancillaries, fuel, oil, water, driver and crew. **Kerb mass** = The weight of the complete vehicle and all equipment including fuel and water, but without payload, driver or any crew. **Plated mass** = The maximum weight allowed to be imposed on the axle (GVM must not be exceeded). **GTM** = Gross train mass. The total permissible all-up weight of a rigid vehicle (see GVM) together with its trailer and load. All kerb masses quoted in this brochure are subject to manufacturing tolerances and are for vehicles with minimum equipment.

Engine data

	Engine technical features	Maximum power ^o	Maximum torque ^o
2.0 Duratorq TDDi Diesel 74 kW (100 PS) 1998cc	4 cylinders in line; DOHC; 16 valves; alloy cylinder head; direct injection with multipoint fuel injection system; turbocharger with intercooler; electronic throttle; catalytic converter	74 kW (100 PS) at 4000 min ⁻¹ (rpm)	250 Nm at 2000 min ⁻¹ (rpm)
2.4 Duratorq TDDi Diesel 66 kW (90 PS) 2402cc	4 cylinders in line; DOHC; 16 valves; alloy cylinder head; direct injection with multipoint fuel injection system; turbocharger with intercooler; electronic throttle; dual-mass flywheel; catalytic converter	66 kW (90 PS) at 4000 min ⁻¹ (rpm)	220 Nm at 1800 min ⁻¹ (rpm)
2.4 Duratorq TDDi Diesel 85 kW (115 PS) 2402 cc	4 cylinders in line; DOHC; 16 valves; alloy cylinder head; direct injection with multipoint fuel injection system; turbocharger with intercooler; electronic throttle; dual-mass flywheel; catalytic converter	85 kW (115 PS) at 3800 min ⁻¹ (rpm)	285 Nm at 2300 min ⁻¹ (rpm)
2.4 Duratorq TDCi Diesel 101 kW (137 PS) 2402cc	4 cylinders in line; DOHC; 16 valves; alloy cylinder head; direct injection with high-pressure, common rail, multipoint fuel injection system; turbocharger with intercooler and transient torque overboost function; electronic throttle; dual-mass flywheel; catalytic converter	101 kW (137 PS) at 3500 min ⁻¹ (rpm)	375 Nm at 2000 min ⁻¹ (rpm)

^oTested in accordance with ISO 1585. All models are 5-speed manual transmission except for 137 PS diesel which is 6-speed manual.

Mechanical features

	12-seat	15-seat	17-seat
Engine			
Road speed limiter (max. 70 mph) (diesel engines only)	○	○	○
Brakes			
Dual-circuit, with self-adjusting servo-assistance. Front discs and rear drums	●	●	●
Electronic anti-lock brakes (with electronic brake-force distribution)	●	●	●
Front brakes – Brake pad wear indicator	●	●	●
Fuel tank			
80 litres	●	●	●
Steering			
Power-assisted steering	●	●	●
Suspension			
Front, independent MacPherson struts, variable rate coil springs and gas-pressurised shock absorbers.	●	●	●
Rear, leaf springs and gas-pressurised shock absorbers	●	●	●
Front – Anti-roll bar	●	●	●
Axle ratios			
Final drive ratio – 3.77 (Rear-Wheel Drive models with 137 PS engine only)		●	●
– 4.23 (Front-Wheel Drive vehicles only)	●		
– 4.27 (Rear-Wheel Drive models with 137 PS engine only)		●	●
– 4.54 (Front-Wheel Drive vehicles only)	●		
– 4.63 (Rear-Wheel Drive vehicles only)		●	●
– 5.13 (Rear-Wheel Drive vehicles only)		●	●
Turning circle			
Kerb to kerb – 11.9 m, wall to wall 12.5 m	●		
– 13.3 m, wall to wall 14.3 m (wall to wall figure excludes 17-seat Minibus)		●	●

● = Standard, ○ = Option, at extra cost.

Safety and security

	12-seat	15-seat	17-seat
Safety			
Anti-lock brakes – Electronic (with electronic brake-force distribution)	●	●	●
Traction Assist (includes anti-lock brakes) (Traction Assist is standard on 2.4 TDdi 115 PS and 2.4 TDCi 137 PS powertrains). Traction Assist remains an option on 100 PS 12-seat bus	○	○	○
Airbag – Driver	●	●	●
– Outer front passenger*	●	●	●
Exterior mirrors – Enhanced rear vision, power operated and heated	●	●	●
Seat belts – 3-point lap and diagonal inertia reel with grabbers (all front seats)	●	●	●
– 3-point lap and diagonal inertia reel with grabbers (all rear seats)	●	●	●
– Height-adjustable 'Generation' rear seat belts	●	●	●
– Height-adjustable seat belt mount (driver only)	●	●	●
– Height-adjustable seat belt mount (outer front passenger)	●	●	●
Security			
Audio – 'Keycode' anti-theft coding	●	●	●
– Removable control panel	●	●	●
Alarm – Perimeter		○	○
Fuel cap – Locking	●	●	●
Immobiliser – 'Safeguard' Passive Anti-Theft System – (certified to Thatcham Category 2)	●	●	●
Locks – High security, lock-in-latch system, shielded with strengthened mountings	●	●	●
– Remote keyless entry central locking		●	●
– Manual locks	●		
– Key-operated bonnet release	●	●	●
Steering wheel – Torque slip, anti-theft	●	●	●
Vehicle Identification Number – Visible	●	●	●

● = Standard, ○ = Option, at extra cost. *Note: A rear-facing child seat should never be placed in the front passenger's seat when the Ford vehicle is equipped with a front passenger's or side airbags.

Exterior features

	12-seat	15-seat	17-seat
Exterior appearance and styling			
Body – Medium roof	●	●	●
Bodyside mouldings	○	○	○
Bumpers – Full width, front and rear	●	●	●
Paint – Metallic	○	○	○
Tyres – Goodyear (Mud and snow) (not available with Alloy wheel option)	○	○	○
– Michelin (All-weather) (not available with Alloy wheel option)	○	○	○
Wheels – 5½x15" steel wheels with centre hub covers and 195/70R 15C tyres (front-wheel drive vehicles only)	●	●	●
– 5½x16" alloy wheels (steel spare) and 205/65R 16C tyres	○	○	○
– 5½x16" steel wheels with centre hub covers and 215/75R 16C tyres (rear-wheel drive only)	○	●	○
– 5x16" steel wheels, dual rear with centre hub covers and 185/75R 16C tyres (rear-wheel drive only)	○	○	●
– Partial wheelcovers	○	○	○
Exterior functional			
Doors – Left-hand sliding side door (high/wide) (a step is only fitted to 15- and 17-seat Minibus)	●	●	●
– Right-hand sliding side door (high/wide)	●	●	●
– Glazed rear doors (includes rear-view mirror) 180° opening, positive stop at 90°	●	●	●
Exterior mirrors – Power-operated and heated	●	●	●
Mudflaps – Front	○	○	○
Mudflaps – Rear	○	○	○
Rear step	○	●	●
Rear step – Integrated in bumper	○	○	○
Rear parking distance sensor (includes integrated bumper step) (not available with optional tow bar or rear centre step)	○	○	○
Towing eyes – Front and rear	●	●	●
Windows – Front, power-operated	●	●	●
– Heated rear	●	●	●
– 2nd row, right-hand side, fixed	○	○	○
– 2nd row, right-hand side, sliding	●	●	●
– 2nd row, left-hand side, fixed	○	○	○
– 2nd row, left-hand side, sliding	●	●	●
– 3rd row, left-hand and right-hand side, rear quarter, opening (fixed – 12-seat Minibus, hinged – 15- and 17-seat Minibus)	●	●	●
Glass – Clear windscreen/light tint passenger glass	●	●	●
– Light tint windscreen/dark tint passenger glass	○	○	○
Windscreen – Laminated	●	●	●
– 'Quickclear' heated	○	○	○
Wipers – Front, two-speed with electric wash	●	●	●
– Twin rear, with electric wash (includes heated rear windows)	●	●	●
Exterior lighting			
Halogen headlights, side lights, rear fog lights, reversing lights	●	●	●
Front fog lights	○	○	○
Headlight levelling	●	●	●
High-mounted rear brake light	●	●	●

● = Standard, ○ = Option, at extra cost.

Interior features

	12-seat	15-seat	17-seat
Audio			
Stereo radio/cassette – Model 4000 RDS, 'Keycode' anti-theft coding, removable control panel, 4 speakers	●	●	●
Stereo radio/CD – Model 6000 RDS, 'Keycode' anti-theft coding, removable control panel, 4 speakers	○	○	○
Carpet and trim			
Cab floor mat – Rubber	●	●	●
Cab headlining – Moulded	●	●	●
Door trim – Front, moulded with pull handles and storage pockets	●	●	●
Rubber floor mat – Full length	●	●	●
Headlining – Moulded full length	●	●	●
Interior lighting			
Courtesy lights – Header-mounted, front door-operated	●	●	●
Passenger area light(s)	●	●	●
Instruments and controls			
Battery – Twin	●	●	●
Cold start (Thermostart for -20°C starting)	●	●	●
Control stalks – Column-mounted for indicators and wash/wipe functions	●	●	●
Illuminated heater controls – 3-speed fan. Four vents with temperature and direction control, two dedicated side window demisters	●	●	●
Instruments – Speedometer, tachometer, odometer, fuel gauge, water temperature gauge, trip recorder	●	●	●
Tachograph – Electronic, 24-hour*	○	○	○
Warning lights for oil pressure, direction indicator, main beam, lights on, ignition/alternator, brake failure, ABS, airbag(s), glow plugs, oil change, low fuel, traction control (where fitted)	●	●	●
Seats			
Seat trim – Fabric	●	●	●
Seats – Fabric trim; driver's 6-way manual adjustment with armrests; dual fixed passengers' seat; height-adjustable head restraints	●	●	●
– Fabric trim; driver's 6-way manual adjustment with armrests; single passenger's 4-way manual adjust seat with armrests; height-adjustable head restraints	○	○	○
– Fabric trim; driver's heated, 8-way manual adjustment with armrests; dual fixed passengers' seat; height-adjustable head restraints	○	○	○
Second row – Dual narrow seat	○	○	○
– Triple narrow seat	●	●	●
Third row – Single/double seat	●	●	●
Fourth row – Single/double seat	○	○	○
– Triple narrow seat	●	●	●
Fifth row – Single/double seat	○	○	○
Sixth row – Single/double seat	○	○	○
Seat belts – Height-adjustable mount, driver's side	●	●	●
– Height-adjustable mount, Outer Front passenger	●	●	●
Comfort and convenience			
Accessory socket 12V	○	○	○
Air conditioning – Front, CFC-free (includes tinted glass)	○	○	○
– Rear, CFC-free (includes tinted glass) (only available with front air conditioning)	○	○	○
Rear compartment heating (not available with rear air conditioning)	○	○	○
Clock – Digital	●	●	●
Cup holder – Twin, facia-mounted, drop-down	●	●	●
Glovebox – With lid	●	●	●
Heater – Recirculation	●	●	●
Smokers' Pack – Cigar lighter and ashtray	○	○	○
Storage – Front door pockets	●	●	●
– Facia-mounted on passenger's side, with cup holder	●	●	●
– Centre facia-mounted document holder, with integral cover	●	●	●
– Facia-mounted stowage slot	●	●	●
Sun visors – Two, swivelling	●	●	●

● = Standard, ○ = Option, at extra cost. *Tachograph When a vehicle is fitted with a trailer towing attachment, it is recommended that a tachograph is fitted, since the ability to tow a trailer giving a GTM of over 3500 kg without a tachograph could be considered to be contrary to EU and UK road traffic law. **1986 Construction and Use Regulations (Schedule 6 and 7)** Transit bus models, over 9-seats, are equipped to meet 1986 Construction and Use Regulations (Schedule 6 and 7) and are certified for PSV application in England, Scotland and Wales. Additional equipment includes: 'A' pillar passenger grab handle; Front passenger doorstep illumination; Side load door with passenger assist grab handle; Side and rear doorstep illumination; Seating capacity decals; Fire extinguisher; First Aid Kit plus location decals; Emergency exit and door operation decals, and passenger carrying capacity decals.

For more information

To find the location of your nearest Ford Transit Specialist Dealer, simply call the Ford Information Service on **0845 7111 888**, or visit the Ford Dealer locator at www.fordvans.co.uk